

UNFINISHED
Pabellón español · Spanish Pavillion

Matadero Madrid, Nave 8B

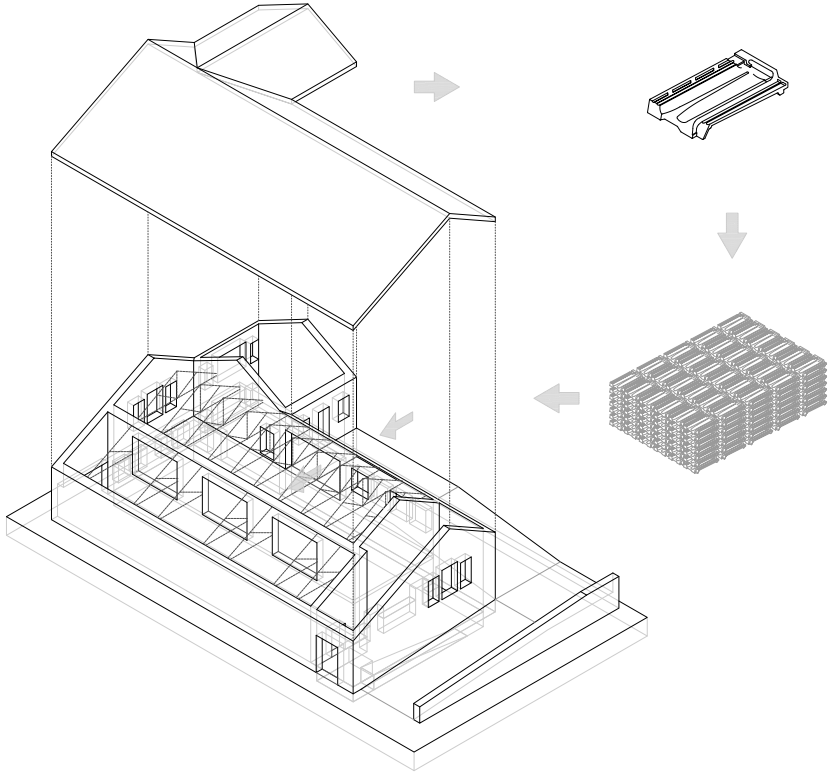

Arturo Franco

Biennale Architettura 2016
La Biennale di Venezia

En una pequeña nave del antiguo matadero de Madrid, la nave 8 B, se han retirado las tejas de una cubierta en mal estado, se han apilado y se han introducido dentro para resolver una necesidad. La nave 8 B será el espacio destinado a la gestión administrativa. Una pequeña zona de trabajo, un almacén y un espacio polivalente para charlas o presentaciones. Una nave menor pero de gran interés espacial. Es una intervención que pretende respetar una configuración espacial válida, sin adulterarla. Es una prueba. Este proyecto deshace algunos caminos recorridos, pretende alcanzar puntos de encuentro. Los elementos industriales, inertes, se entienden de otra manera, descontextualizados y colocados desde la imprevisibilidad del trabajo manual. Se utilizan las tejas de otra forma. Este proyecto pretende entender la arquitectura como una experiencia intelectual, cultural, ética.

In Building 8 B, a small building within the former slaughterhouse complex in Madrid, the clay roof tiles have been removed from a roof that needed to be replaced and stacked up inside of the space to solve a problem. Building 8 B is programmed to be an administrative space, with a small work space, a storage area and a multipurpose space for talks or presentations. It is a small building, but spatially very interesting. This intervention aims to respect a valid spatial configuration, with no adulteration. It is a test. This project retraces some paths that were taken, trying to find meeting points. The inert industrial elements are understood differently, decontextualized and installed with the unpredictability of manual labour. The tiles are used in another way. This project tries to understand architecture as an intellectual, cultural and ethical experience.













Plantas · Plans

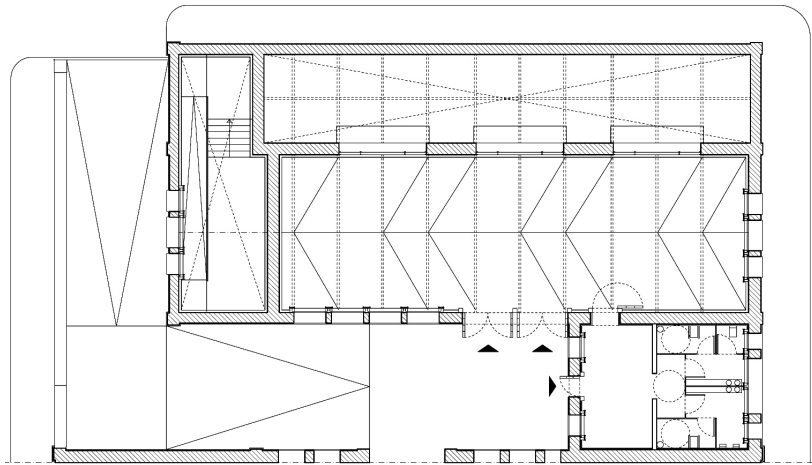
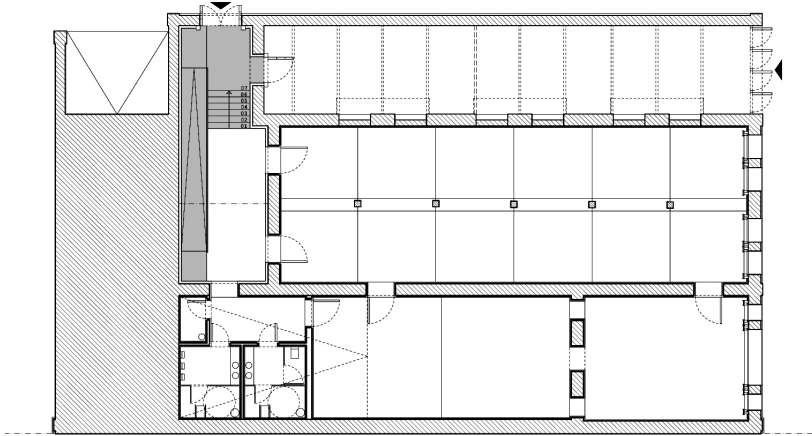

Secciones · Sections

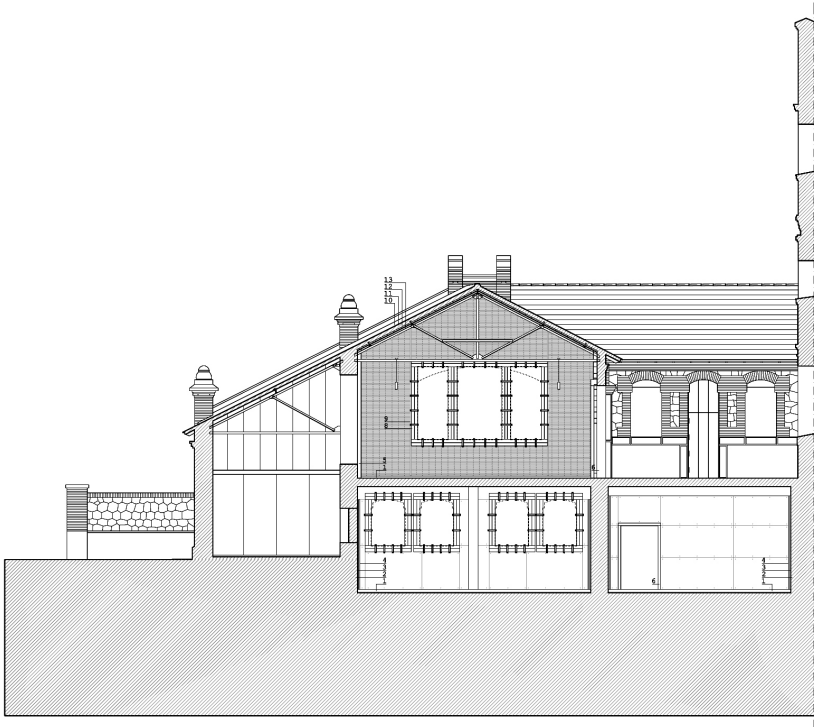
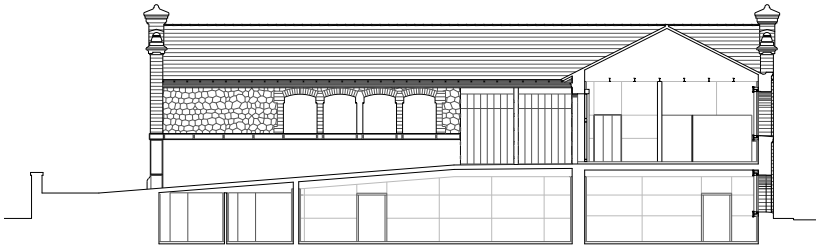
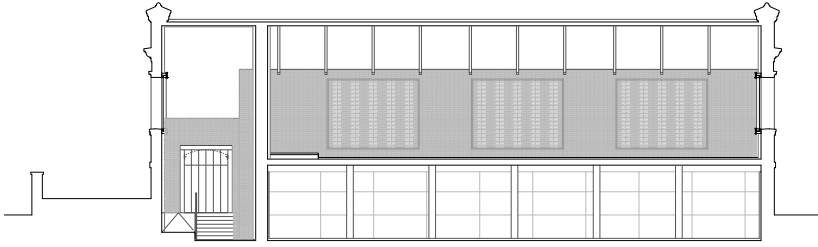

Matadero Madrid, Nave 8B-
Matadero Madrid, Building
8B

Localización- Location:
C/ Paseo de la Chopera, 14,
Matadero Madrid. 28045
Madrid

Arquitecto- Architect:
Arturo Franco

Colaboradores- Team:
Arquitectos, architects:
Yolanda Ferrero, Diego
Castellanos; Arquitecto
técnico, Technical architect:
Jose H. Largo Díaz;
Estructuras, structures:
Juan Rey, Mecanismo SL.

Superficie- Area:
1000 m²

Fotografía- Photography:
Carlos Fernández Piñar

2009